

Introduction

For the following signs, these instructions show how to change the serial address, serial communication settings (data bits, parity, and stop bits), and display parameters (display test and memory clear); how to mount; and how to connect a computer:

	Full matrix	Character matrix
Model number	FMvvvvvvP03zzz	CMxxxxyyP03zzz
Number of LED columns (vvi)	096, 128, 160, 192, 224, or 256	—
Number of LED rows (www)	032, 048, 064, 080, 096, 112, or 128	—
Characters/line (xxx)	—	024, 032, 040, or 048
Number of lines (yyy)	—	004, 006, 008, 010, or 012
LED color (zzz)	RED, SBR (superbright red), or TRI (tri-color)	

Changing the serial address

The address of an ALPHAVISION full matrix or character matrix sign is set by changing a DIP switch that is accessed through the back of the sign. The default serial address is “0”.

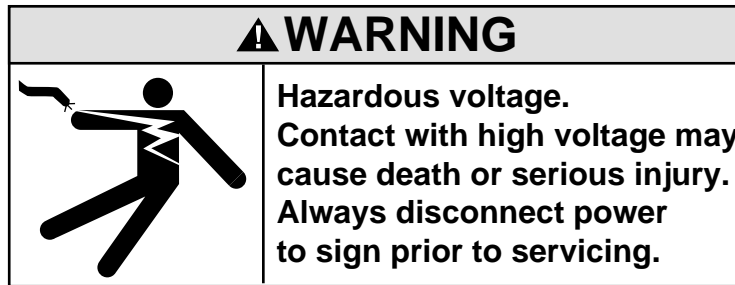

1. Remove power to the sign.
2. Take off the DIP switch cover on the back of the sign and locate the two DIP switches:

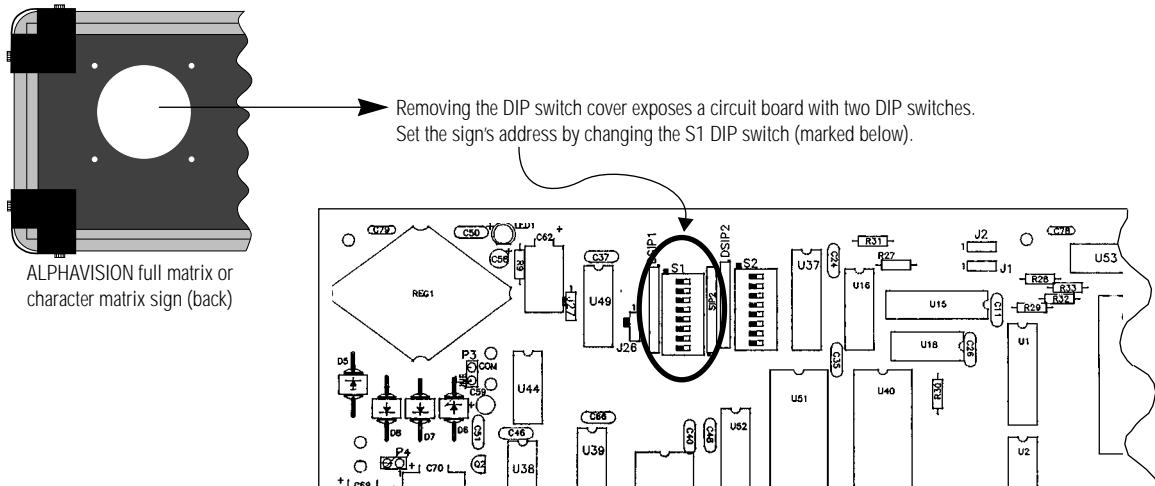

Figure 1: DIP switch locations

Changing serial communication settings (data bits, parity, and stop bits)

The two communication protocol settings are:

- **7E2** (7 data bits, even parity, and 2 stop bits) — This is the default or “factory” setting.
- **8N1** (8 data bits, no parity, and 1 stop bit) — Use this setting when an AMS Data Receiver is attached to the sign for paging applications.

To change the serial communication setting, follow these directions:

1. Follow steps 1 and 2 in the previous “Changing the serial address” on page 1.
2. Set the serial communication protocol by setting switch #1 on the **S2** DIP switch:

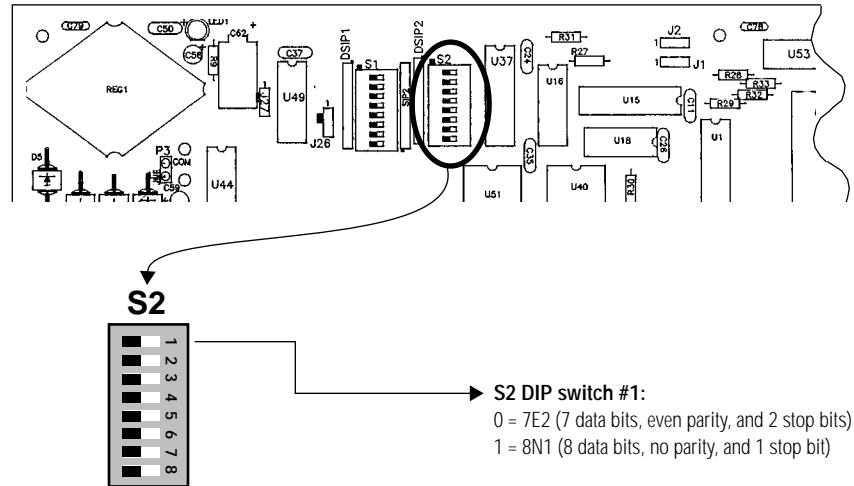

Figure 2: Using the S2 DIP switch to set a serial communication protocol

Changing display parameters

By changing the settings on the S2 DIP switch, memory can be automatically cleared on power up and/or test patterns can be displayed on the sign. To change any of these parameters, follow these directions:

1. Follow steps 1 and 2 in the previous “Changing the serial address” on page 1.
2. Set the display parameters by setting switches #7 and 8 on the S2 DIP switch:

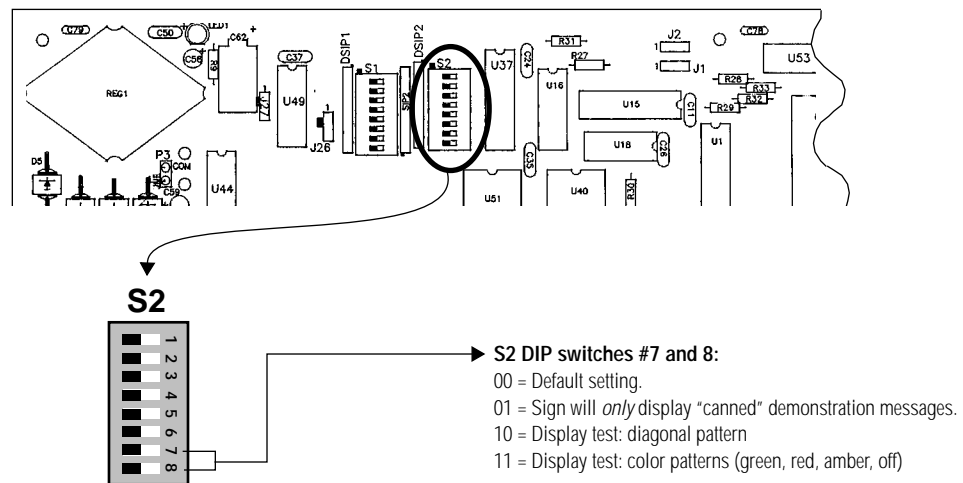

Figure 3: Using the S2 DIP switch to set display parameters

Installation instructions

ALPHAVISION full matrix and character matrix signs are for *indoor use only* and should not be continuously exposed to direct sunlight. These signs should only be used in an environment where the temperature is between 0 and 49 degrees Celsius and the humidity (non-condensing) does not exceed 95%.

AMS recommends the following procedures be used to decrease the amount of electrical noise surrounding ALPHAVISION full matrix and character matrix signs:

- A sign should be connected to its own branch circuit.
- The input power source should be protected by a circuit breaker rated at no more than 20 amperes per sign.
- Incoming power to a sign should be routed on a path separate from a sign's communication cables. Do NOT run the power and signal wires in the same conduit.
- Where power and communications lines must cross, the intersection should be perpendicular.
- All communication lines should be shielded. The shield should only be connected to ground at the transmitting device.

Wall mounting

Required tools

Table 2: Required tools for wall mounting

Tool	AMS Part #
7/16" socket - 3/8" torque wrench	—
Phillips head screwdriver	—
Drill and drill bits	—

Mounting kits

Obtain a wall mounting kit for your sign from AMS using the following table as a guide:

Table 3: ALPHAVISION wall mounting kits

For this type of sign...		...order this kit:
Full matrix	96 columns wide	PN 10209010A
	128 columns wide	PN 10209010B
	160 columns wide	PN 10209010C
	192 columns wide	PN 10209010D
	224 columns wide	PN 10209010E
	256 columns wide	PN 10209010F
Character matrix	24 characters wide	PN 10209011A
	32 characters wide	PN 10209011B
	40 characters wide	PN 10209011C
	48 characters wide	PN 10209011D

NOTE: The mounting kits in Table 3 do *not* include fasteners for attaching the wall bracket to a wall. The exact type of fastener used will vary, depending on the type of wall (e.g., concrete, brick, drywall, etc.) to which the sign is mounted. The fasteners used *must* be capable of supporting 800 lbs. (363 Kg.).

NOTE: A sign must be attached to a wall capable of supporting 1250 lbs. (567 Kg.).

Directions

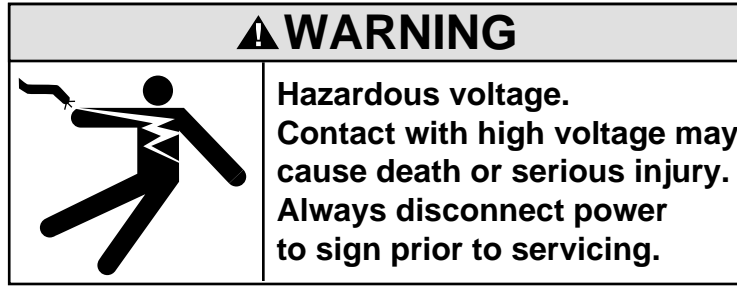

1. Remove power from the sign.
2. Remove the four screws from each back corner of the sign at "B" and "C" (see Figure 4):

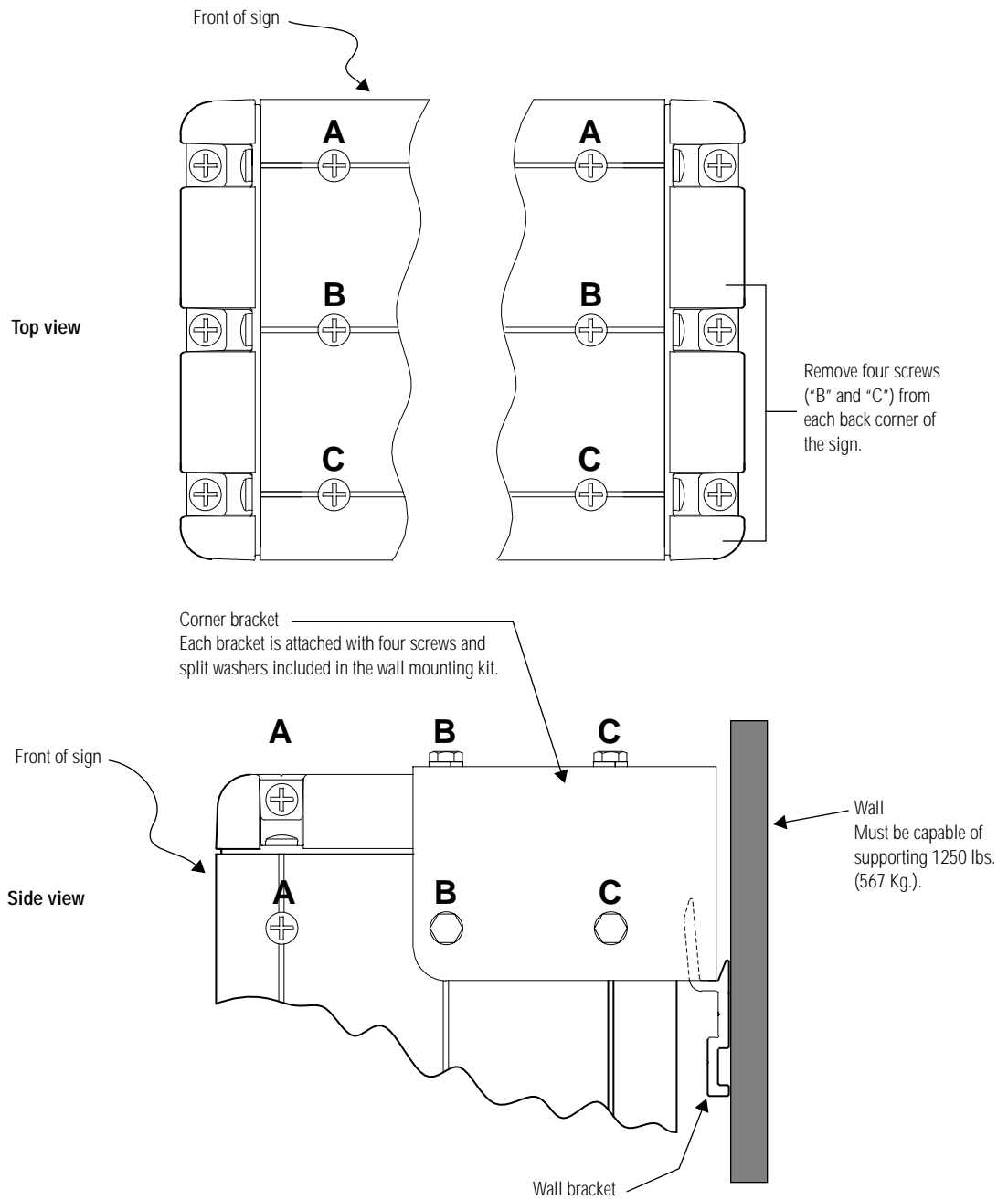

Figure 4: Wall mounting the sign

- Attach a corner bracket (included with the wall mounting kit) to the back corner of each side of the sign. Use four bolts with split washers (included with the wall mounting kit) to attach each bracket (see Figure 4). Torque each bolt to 50 - 60 foot-pounds (5.7 - 6.8 Nm).
- Drill at least six holes into the wall bracket (included with the wall mounting kit) and fasten the wall bracket to a wall capable of supporting 1250 lbs. (567 Kg.). Make sure that the pointed end of the wall bracket faces up.

NOTE: The wall bracket fasteners are NOT included with the wall mounting kit. Make sure that the fasteners you select are appropriate for the type of wall to which the sign will be mounted. Also, make sure that the fasteners are capable of supporting 800 lbs. (363 Kg.).

- Mount the sign to the wall by lifting the sign so that the corner brackets rest on the wall bracket.

Overhead suspension

Required tools

Table 4: Required tools for overhead suspension

Tool	AMS Part #
Phillips head screwdriver	—
Adjustable wrench	—

Mounting kit

The overhead mounting kit is included with your sign:

Table 5: ALPHAVISION overhead suspension mounting kit

Quantity	Item
4	1/4 - 20 x 2.50" (63.5 mm) long, stainless steel eyebolts
4	1/4 - 20 hex stop nuts
4	1.00" (25.4 mm) O.D. fender washers

You must supply the following items:

Table 6: Customer supplied items for suspension mounting

Quantity	Item
4	chains, each capable of supporting 800 lbs. (363 Kg.)
4	0.25" (6.4 mm) diameter locking quick links, each having a working load limit of no less than 1250 lbs (567 Kg.).

Directions

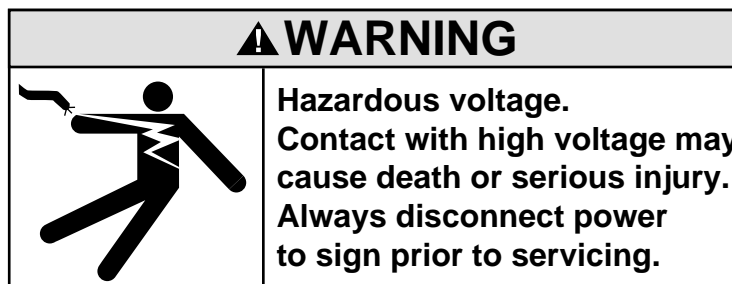

- Remove power from the sign.

- Remove the screws labeled “A” and “B” and attach the four eyebolts (see Figure 5):

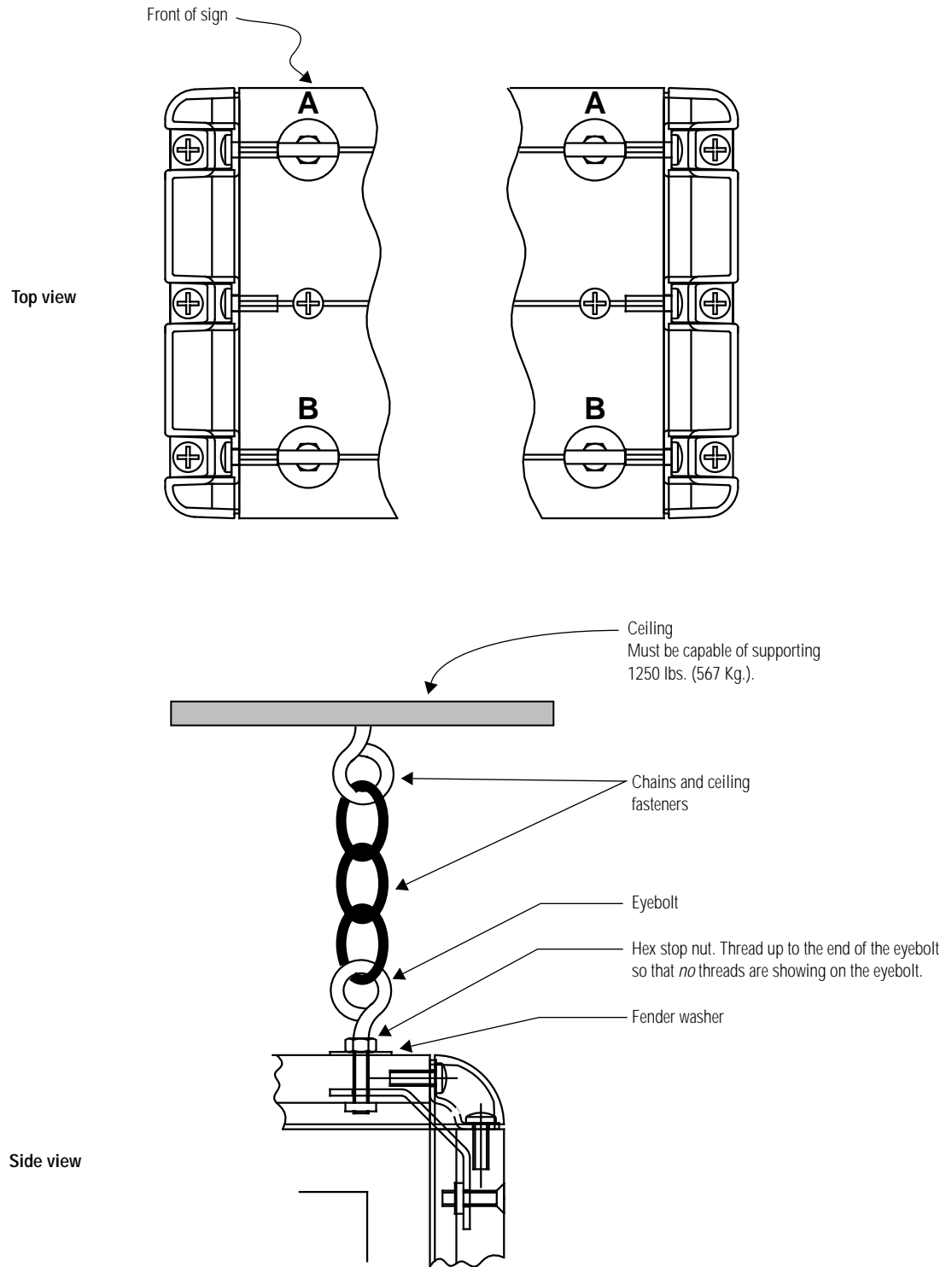

Figure 5: Suspending the sign

- After inserting all four eyebolts (with hex stop nuts attached), wrench-tighten the stop nuts down onto the fender washers.
- Suspend sign from the four eyebolts using four, appropriate chain and wall fasteners.

Connecting a computer to a sign

In order to display messages on the sign, a computer using AlphaNET *plus* software must be connected to the sign. The software is used to create and to send the messages to the sign.

The following example shows how to connect a single computer to a single sign. However, there are many other ways to connect signs such as networking multiple signs together. For further information on networking signs, see AMS's **Network Configurations** manual (part number 9708-8046).

Table 7: Connecting a single sign to a PC

